

# **Y-Not**

**User's Manual**



**RJM Music Technology, Inc.**



# **Y-Not**

## **User's Manual**

Version 1.0  
November 18, 2009

RJM Music Technology, Inc.  
2525 Pioneer Ave #1  
Vista, CA 92081  
E-mail: [support@rjmmusic.com](mailto:support@rjmmusic.com)  
Web: [www.rjmmusic.com](http://www.rjmmusic.com)

Copyright © 2009 RJM Music Technology, Inc. All Rights Reserved.

Amp Gizmo, Effect Gizmo, Mini Amp Gizmo, MasterMind, RG-16,  
Y-Not and the RJM logo are trademarks of  
RJM Music Technology, Inc.

# Table of Contents

<b>INTRODUCTION</b>	<b>1</b>
<b>FRONT PANEL</b>	<b>2</b>
<b>BACK PANEL</b>	<b>4</b>
<b>MIDI USAGE</b>	<b>5</b>
<b>Continuous Controllers</b>	<b>6</b>
<b>Bank Selection</b>	<b>6</b>
<b>SETUP MODE</b>	<b>7</b>
<b>Selecting MIDI Channel</b>	<b>7</b>
Saving MIDI Channel	7
<b>Selecting Other Options</b>	<b>7</b>
Switch Invert	8
Bank Select Enable	8
Saving Options	8
<b>TROUBLESHOOTING</b>	<b>9</b>
<b>SPECIFICATIONS</b>	<b>10</b>
<b>WARRANTY</b>	<b>11</b>

## **Introduction**

Thank you for purchasing a Y-Not. This product is designed to provide all of the features you need to switch one audio signal to two audio outputs, while being able to address the common problems that can occur in a two-amp system. The Y-Not features a high-quality buffer, a phase inversion switch and an isolation transformer all in a compact package.

The Y-Not can be controlled by its front panel switches, by an external footswitch or by an external MIDI controller, making it adaptable to virtually any situation.

## Front Panel

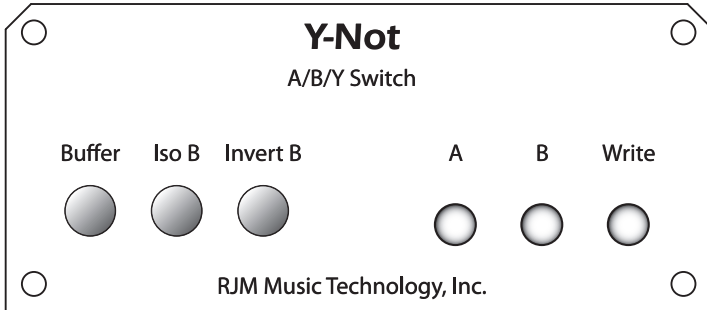

**Buffer** – When this button is in, the input signal will go through a high-quality audio buffer. A buffer lowers the impedance of the input signal, making it “stronger” and preventing it from losing treble or signal level when splitting the signal to two outputs. When this button is out, the buffer is disconnected from the signal path.

If you find your signal sounds dull or muted, try engaging the buffer. Unless your signal is already buffered, you will likely want to use the buffer when using the Iso or Invert buttons (below).

**Iso B** – When this button is pressed in, it inserts an isolation transformer in front of the B output. The isolation transformer breaks ground loops between the two amps. Ground loops are a common occurrence when using more than one amp, and you can tell you have a ground loop if you hear an unusually large amount of hum or buzz from your amps. Pressing the Iso B button should break the ground loop and eliminate the hum.

**Invert B** – This button inverts the phase of the B output. This can come in handy when using two amps at once. Depending on the position of each amp and their individual design, you may hear phase cancellations, resulting in poor tone or diminished volume levels. Inverting the phase of one amp may fix the phase cancellations and create a more desirable sound.

You may also have need for the Invert B button when using the Y-Not to connect to two different inputs of the same amp. Certain amps have a phase inversion between the two inputs, making it impossible to run both inputs at once – unless you have a way to invert the phase of one signal. If you're running the Y-Not with a two input amp and notice a volume decrease when running both inputs simultaneously, try turning on the Invert B button - it should resolve the problem.

**A** – This button turns the A output on and off. When this button is lit, the A output is on. When this button is not lit, the A output is off (shorted to ground).

**B** – This button turns the B output on and off. When this button is lit, the B output is on. When this button is not lit, the B output is off (shorted to ground).

**Write** – When held down for 3 seconds, this button saves the current switch state to non-volatile memory. This function is not active until a Program Change message is received at the MIDI In jack. See the MIDI Usage section for more details.

The Write button is always lit up with a green LED to indicate that the Y-Not is powered on.



## Back Panel

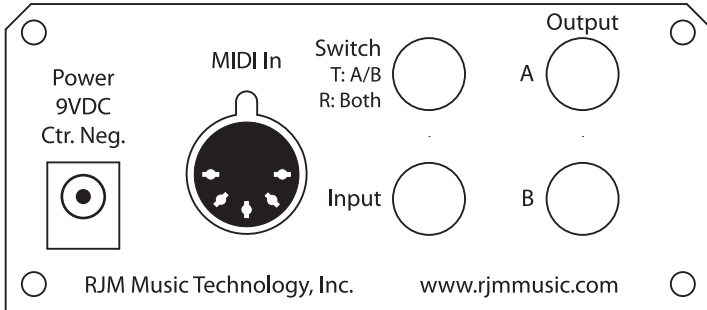

**Power** – This unit requires a 9 volt DC power supply (center negative polarity). The plug should be a 5.5mm/2.1mm barrel connector, similar to those used in most effects pedals. The Y-Not requires a minimum of 150mA of current.

**MIDI In** – Jack for incoming MIDI commands. Connect your MIDI foot controller or other MIDI device here.

**Switch** – You can connect a two-button footswitch or other external switching device to this jack. The tip conductor of this jack turns the B output on when shorted to ground, and the A output on when not shorted to ground. The ring conductor, when shorted to ground, turns on both the A and B outputs simultaneously.

**Input** – Connect your input signal (guitar or other audio signal) here.

**A** – This is the first (A) output from the Y-Not, controlled by the A switch on the front panel.

**B** – This is the second (B) output from the Y-Not, controlled by the B switch on the front panel.

## MIDI Usage

The Y-Not can receive MIDI messages from any MIDI controller. You can store different switch settings for MIDI program numbers 1 through 128 in MIDI banks 0 and 1. When a Program Change message is received on the correct channel, the Y-Not will automatically recall the saved settings for the given program number.

To set up for MIDI use, simply connect your MIDI controller to your Y-Not's MIDI In jack. The Y-Not is set for MIDI Channel 1 by default. Either make sure your MIDI controller is set up to transmit commands on Channel 1, or use the Y-Not's setup mode to change which MIDI channel the Y-Not responds to. See the Setup Mode section for more details.

To save a program setting, perform the following steps:

1. Using your MIDI controller, select a MIDI program number.
2. Using the Y-Not buttons, turn the A and B outputs on or off as desired.
3. Hold down the Write button on the Y-Not until the LEDs flash. This should take about 3 seconds.

That's all it takes. You can repeat this for any or all of MIDI program numbers 1 through 128.

If the lights don't flash after a few seconds of holding down the Write button, it means that your Y-Not did not receive the MIDI Program Change message. Check your MIDI cable connection, and make sure that the MIDI controller and Y-Not are set to the same MIDI channel.

Now that your settings have been saved, you can recall your settings by using your MIDI controller to send a Program Change message again. The Y-Not will call up your saved settings and select the desired active output(s) whenever it receives a MIDI Program Change message.

## ***Continuous Controllers***

In addition to supporting MIDI Program Change messages, the Y-Not supports MIDI Continuous Controller messages. The following Continuous Controllers are supported by default:

<b>Continuous Controller</b>	<b>Value</b>	<b>Function</b>
CC88	0...63 64...127	A output off A output on
CC89	0...63 64...127	B output off B output on
CC90	0...63 64...127	A output on, B output off A output off, B output on
CC91	0...63 64...127	A and B outputs off A and B outputs on

## ***Bank Selection***

The Y-Not can store programs in MIDI banks 0 and 1, for a total of 256 programs. Continuous Controller #0 (Bank MSB) is used to select the current MIDI bank. Bank numbers above bank 1 are ignored.

By default, bank selection is disabled. You can enable bank selection using Setup Mode (see Setup Mode section).

## Setup Mode

To configure the Y-Not, you must first enter setup mode. Holding down selected buttons while powering the unit on will bring up selected setup modes, as detailed in this section.

### *Selecting MIDI Channel*

Hold the A button while powering the Y-Not on. Keep holding the button until the LEDs flash. The Switch buttons will now allow you to select the MIDI channel the Y-Not responds to.

The Y-Not is set by default to send and receive on MIDI Channel 1. To change the send/receive channel:

<b>MIDI Channel</b>	<b>A LED</b>	<b>B LED</b>
<b>1</b>	OFF	OFF
<b>2</b>	<b>ON</b>	OFF
<b>3</b>	OFF	<b>ON</b>
<b>4</b>	<b>ON</b>	<b>ON</b>

### **Saving MIDI Channel**

Once you've set the MIDI channel and options, press the Write button. The Y-Not is now in normal operational mode.

### *Selecting Other Options*

There are two other options that can be set on the Y-Not. To access and change these options, hold the B button while powering on the Y-Not. Keep holding the button until the LEDs flash.

Once you've entered this mode, you can adjust the following settings:

## **Switch Invert**

You can use the A button to invert the sense of the Switch jack. If the A button is lit, the Switch jack is inverted. If not lit, it's set to the normal state.

This is particularly useful if you're using a lighted footswitch to control the Y-Not. Some footswitches will behave the opposite of what you'd expect: the A/B button turns on the A output when lit, and the Both button turns on both outputs when it's *not* lit. Turning on this option makes the footswitch operate normally.

## **Bank Select Enable**

You can use the B button to enable MIDI bank select. If the B button is lit, the Y-Not will respond to MIDI bank select (CC#0, values 0 and 1 only). If the B button is not lit, the Y-Not will ignore MIDI bank select messages.

## **Saving Options**

Once you've set the desired options, press the Write button. The Y-Not is now in normal operational mode.

## Troubleshooting

**Problem:** My guitar sounds muddy or too quiet when running through the Y-Not.

**Solution:** Your signal needs to be buffered. Press the Buffer button on the front of the Y-Not, and you'll be sounding good once again.

**Problem:** When running into an amp with two inputs, the signal level drops when I turn on both the A and B output.

**Solution:** The two inputs of your amp are out of phase with each other. Press the Invert B button to fix the phase inversion. You may also need to press the Buffer button to avoid possible tone loss.

**Problem:** There is excessive hum or buzz.

**Solution:** There is likely a ground loop in your system. Press the Iso B button to engage the isolation transformer. You may also need to press the Buffer button to avoid possible tone loss.

## Specifications

<b>Dimensions</b>	Quarter-rack enclosure 4 (W) x 1.5 (H) x 4 (D) inches 10.2 (W) x 3.8 (H) x 10.2 (D) cm
<b>Weight</b>	10.3 ounces 300 grams
<b>Power</b>	9 Volts DC @ 150mA, center negative 5.5mm OD, 2.1mm ID x 9.5mm barrel connector
<b>Memory</b>	256 programs, arranged in 2 banks of 128  Memory is non-volatile and requires no backup battery

## **Warranty**

RJM Music Technology, Inc. warrants this product against any defects that are due to faulty material or workmanship for a period of one year from the date of original retail purchase. This warranty does not cover damage to the product resulting from accident or misuse.

This warranty is transferable provided the current owner has the original purchase receipt and can provide a copy of it when submitting the warranty claim.

Should you experience any difficulty with this RJM Music product, please contact us as described below. If it is determined that the product has become defective within the warranty period and must be returned to the factory, RJM Music Technology will issue a Returned Merchandise Authorization (RMA) number and shipping and packaging instructions.

RJM Music Technology will repair or replace the product free of charge, provided it is returned freight prepaid to RJM Music Technology with a valid receipt and RMA number. Return shipping will be paid by RJM Music Technology within the U.S. only.

This warranty shall not apply to any goods that have been repaired or altered by anyone other than the manufacturer or authorized service center. There are no warranties which extend beyond the terms described herein.

RJM Music Technology, Inc.  
2525 Pioneer Ave  
Suite 1  
Vista, CA 92081  
Phone: +1 (760) 597-9450  
E-Mail: [support@rjmmusic.com](mailto:support@rjmmusic.com)









